

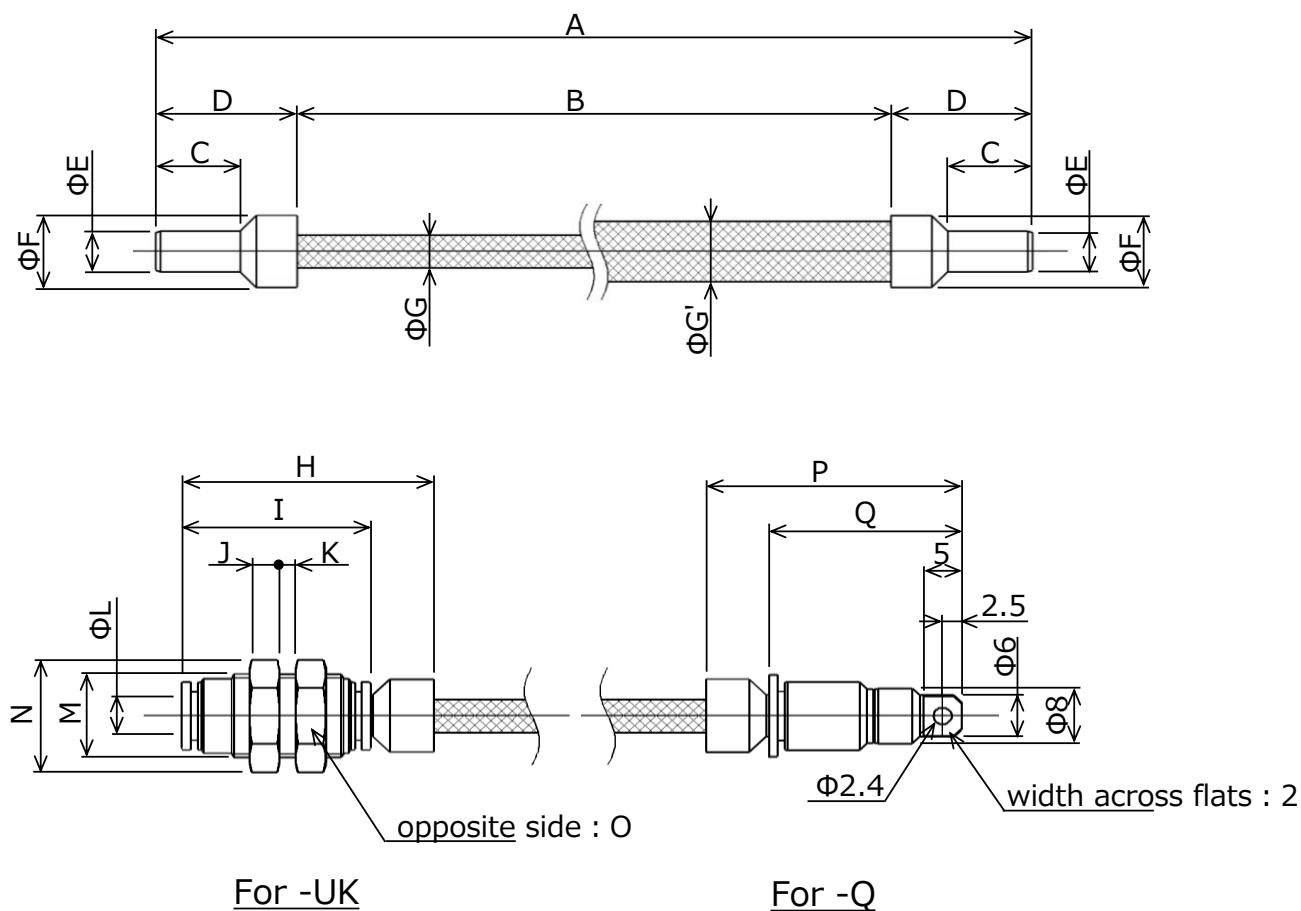

● Dimensions(Pneumatic Artificial Muscle)



For -UK

For -Q

Type	Dimension [mm]										
	A	B	C	D	E	F	G	G'	H	I	J
PMJ20×St-UK-Q	St.+34	St.	11	17	4	7.5	3	5	29.3	23.2	3
PMJ40×St-UK-Q	St.+40	St.	12	20	6	10.5	5	9	33.3	25	4

Type	Dimension [mm]						
	K	L	M		N	O	Q
PMJ20×St-UK-Q	MAX.5	4	M10×1 (fine thread)		(13.9)	12	23.6
PMJ40×St-UK-Q	MAX.5	6	M12×1 (fine thread)		(16.2)	14	25.5

- G' dimension is the dimension when 0.3MPa is applied.
- G dimension and G' dimension are reference values.

For '-UK, the attached tube diameter conversion connector may be required depending on the tul
In that case the dimensions will be different from the above.

2021.06.01